

专业定制快退式多工位供料系统

Specialized Customized Quick Return Multi-station Feeding System

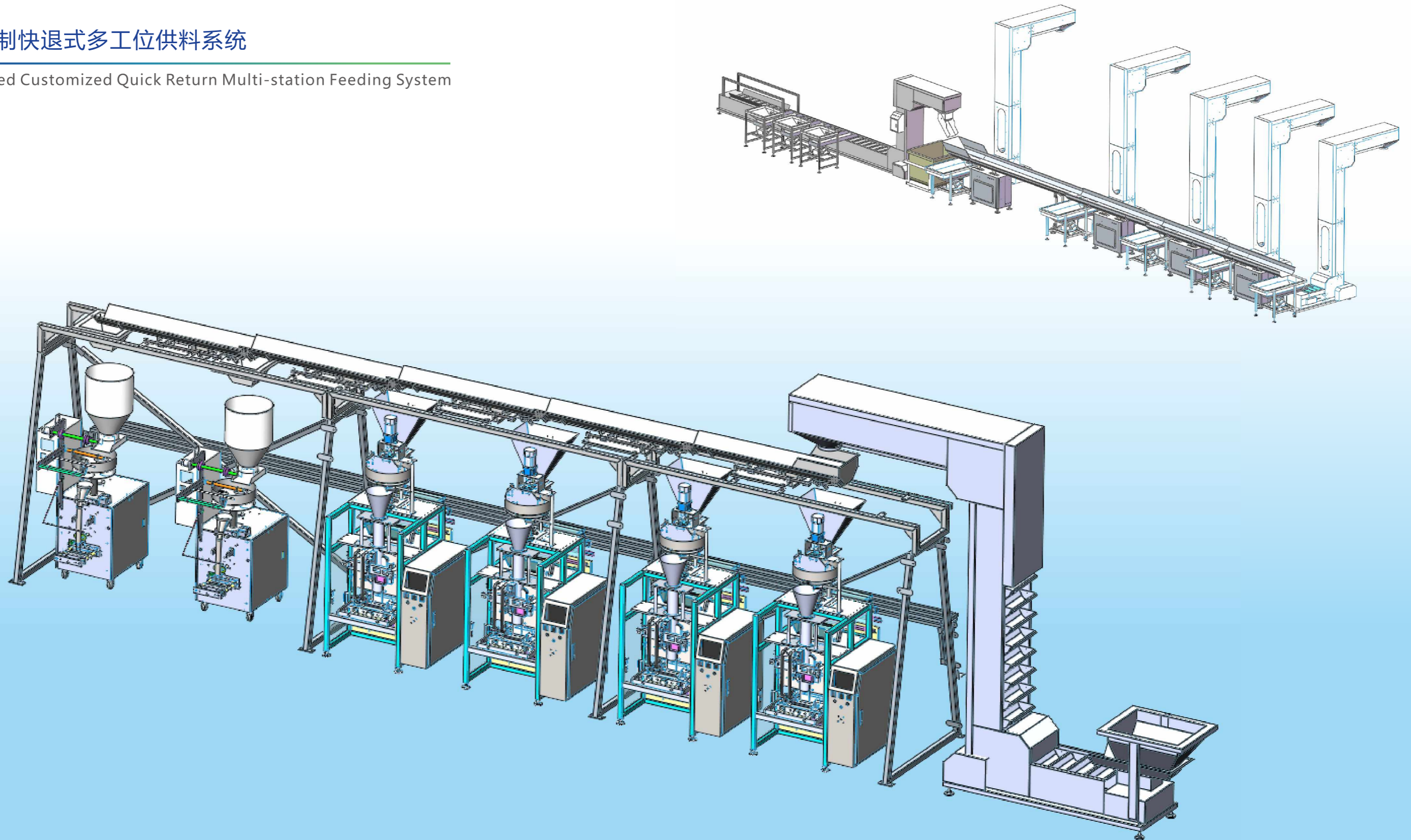

专业定制各类包装生产线及配套设备

Specialized customization of various packaging production lines and supporting equipment

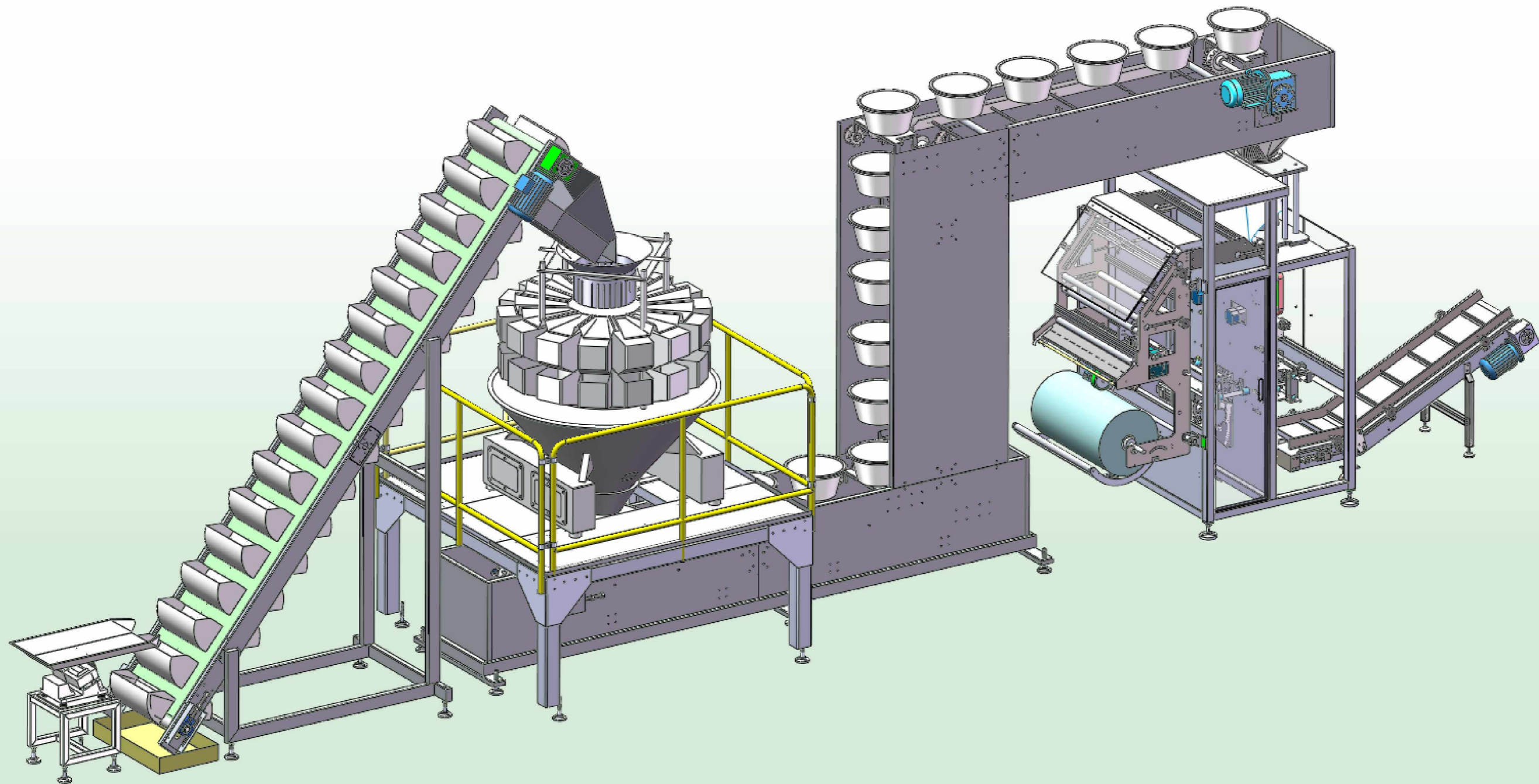



包装机配量杯系列
PACKING MACHINE QUANTITY CUP SERIES



包装机配电子秤系列
PACKAGING MACHINE DISTRIBUTION ELECTRONIC SCALE SERIES



包装机配螺杆系列
PACKAGING MACHINE WITH SCREW SERIES



包装机配灌装泵
PACKING MACHINE WITH FILLING PUMP



立式全自动包装机系列 VERTICAL AUTOMATIC PACKING MACHINE



DBIV-420YT 一体式包装机 GRANULE PACKING MACHINE



可包装的款式 Packaging style

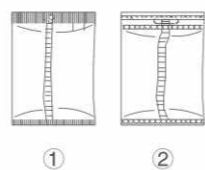

可选配置 Options

- | | | |
|------------------------------|--|----------------------------|
| 1. 插脚装置 Guesst device | 4. 除尘装置 Dust cleaning device | 7. 真空拉膜 Vacuum film |
| 2. 打孔装置 Hole punching device | 5. 自动纠偏装置 Automatic deviation-checking equipment | 8. 充气装置 Gas-filling device |
| 3. "PE"膜装置 "PE"Film device | 6. 连袋装置 Even the bag device | |

主要特征：

1. 连体式称重包装设计：电子组合称与包装机统一操，提高了称重包装速度。
2. 高精度，小目标称重：选择最佳的组合，高精度与高速度的组合。
3. 简易高速操作：微机控制，触摸屏显示，操作维护简便。
4. 简约空间：独特的连体式称重包装设计，最大限度地降低机械的高度，节省了空间。
5. 精确定位：伺服控制拉膜，拉膜定位准确；电眼自动跟踪，商标定位准确。
6. 快速的投资回报：在很大程度上节省了原材料和劳动力成本大的数量。

主要功能：

分料称重、充填、拉膜、制袋、封口、计量、打印、打码、打孔及其它包装辅助等一次完成
应用包装范围：

适合于包装各类膨化易碎的食品、中药饮片。如薯片、锅巴等膨化食品、核桃、榛子、开心果等大壳坚果、糖果、瓜子、情人梅、花生、果仁、巧克力等休闲食品，宠物食品、小五金件等各种颗粒状、块状、球状物料的定量称重。

技术参数 Technical parameters

机型	Type	DBIV-420YT
电子称型号	Weigher Model	DB-10/12
称斗数	Weigher Head	10斗、12斗
称斗容积	Hopper Volume	1.0L
称重范围	Max.cap.(g)	10~1000g
最大称重量	Max weight	1000g
称量精度	Weighing Accuracy (g)	±0.5~1.5g
制袋长度	Bag Length	60~300mm(达到220mm以上分两次运膜)
制袋宽度	Bag Width	60~200mm
卷膜宽度	The Width of Roll Film	420mm
包装速度	Packing Speed	5~60包/分钟
气压	Air Consumption	0.65mpa
耗气量	Gas Consumption	0.6m ³ /min
电压	Power Voltage	220V/50HZ
功率	Power	5.0KW
外型尺寸	Dimension	(L)1450×(W)1050×(H)2400mm
机器重量	Net Weight	500kg



DBIV-1200/1000/820/720 立式全自动包装机 VERTICAL AUTOMATIC PACKING MACHINE



可包装的款式 Packaging style

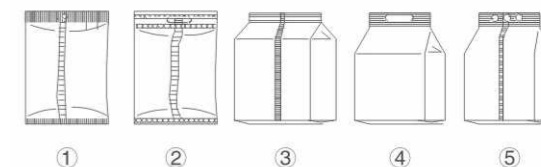

技术参数 Technical parameters

机型(Type)	DBIV-1200	DBIV-1000	DBIV-820	DBIV-720
薄膜最大宽度(max width of roll film)	1250mm	1000mm	820mm	720mm
制袋宽度(Bag-making size)	400~600mm	300~500mm	250~400mm	200~350mm
袋长(最长)(Bag length)	600mm	600mm	500mm	500mm
计量范围(Measuring range)	10~50升	2~30升	2~25升	2~20升
包装速度(Packaging speed)	2~20(bag/min)	2~30(bag/min)	2~30(bag/min)	2~30(bag/min)
包装材料(Packing material)	OPP/CPP OPP/CE PET/PE PE			
电压(Power voltage)	220VAC/50HZ			
功率(Power)	7.5KW	6KW	5.5KW	5KW
外形尺寸(Dimension)LxWxH(mm)	1685×1730×2540	1685×1730×2540	1685×1730×2540	1658×1380×2046
机器重量(Net weight)	900Kg	850Kg	800Kg	700Kg

产品特点 Technical characteristics

1. 全中文(或英文)显示(各国文字可根据客户要求设置)；
2. 西门子触摸屏清楚显示各工作状态、操作指示等，操作简便直观；
3. 西门子PLC提供稳定的工作程序；
4. 可预置10个产品的配方，适应快速更换产品的包装；
5. 采用智能温控器，温差可控制在2度以内；
6. 不停机可直接在触摸屏上调整封切位置，纠偏等；
7. 配合横纹齿型封口，包装更加牢固；还可选用直纹、斜纹、网纹等；
8. 可采用CE安装标准，电箱防护标准可达IP65；
9. 该包装机能制多种袋型，如：平面袋(背封、三边封、四边封)、立体袋(插口自立袋、三角袋)、手提袋、冲孔袋；

- Chinese (or English)screen display , (the countries words can according to the requirements of the customers).
- Simens PLC clearly show the working state, handle direction and so on, simple operation directly .
- Simens PLC system provide a stable work procedures.
- It can stock ten dispose, fit to the change of the product packing fastly.
- Using intellect thermostat , can control the temperature within 2°C.
- Adjust the seal position in the touch screen ,do not need to stop the machine, deviation and so on ,(more than 4230 can choose the automatic deviation).
- Cooperate with horizontal grain tooth type sealing, packing more firm, also can choose straight grain , twill. cobwebbing, etc.
- Use the CE installation standard, the protect standard can be IP65.
- The packing function of a variety of bag type: such as: flat bags (pillow bag , three sides seal, four sides seal), solid bag (jack stand-up pouches, triangle bags), handbags, punching bags.

立式全自动包装机系列 VERTICAL AUTOMATIC PACKING MACHINE



DBIV-620/520/420/320

立式全自动包装机

VERTICAL AUTOMATIC PACKING MACHINE



可包装的款式 Packaging style

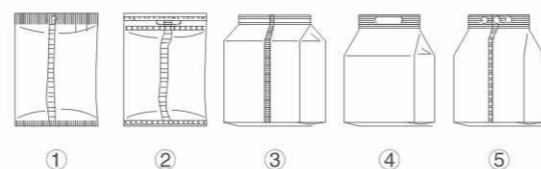

可选配置 Options

- 1. 插脚装置 Guesst device
- 2. 打孔装置 Hole punching device
- 3. "PE"膜装置 "PE"Film device
- 4. 除尘装置 Dust cleaning device
- 5. 自动纠偏装置 Automatic deviation-checking equipment
- 6. 连袋装置 Even the bag device
- 7. 真空拉膜 Vacuum film
- 8. 充气装置 Gas-filling device

产品特点 Technical characteristics

- 1. 全中文 (或英文) 显示(各国文字可根据客户要求设置) ;
- 2. 西门子触摸屏清楚显示各工作状态、操作指示等, 操作简便直观 ;
- 3. 西门子PLC提供稳定的工作程序 ;
- 4. 可预置10个产品的配方, 适应快速更换产品的包装 ;
- 5. 采用智能温控器, 温差可控制在2度以内 ;
- 6. 不停机可直接在触摸屏上调整封切位置, 纠偏等 ;
- 7. 配合横纹齿型封口, 包装更加牢固 ; 还可选用直纹、斜纹、网纹等 ;
- 8. 可采用CE安装标准, 电箱防护标准可达IP65 ;
- 9. 该包装机能制多种袋型, 如: 平面袋 (背封、三边封、四边封)、立体袋 (插口自立袋、三角袋)、手提袋、冲孔袋 ;

·Chinese (or English)screen display , (the countries words can according to the requirements of the customers).
 ·Simens PLC clearly show the working state, handle direction and so on, simple operation directly .
 ·Simens PLC system provide a stable work procedures.
 ·It can stock ten dispose, fit to the change of the product packing fastly.
 ·Using intellect thermostat , can control the temperature within 2°C.
 ·Adjust the seal position in the touch screen ,do not need to stop the machine, deviation and so on ,(more than 4230 can choose the automatic deviation).
 ·Cooperate with horizontal grain tooth type sealing, packing more firm, also can choose straight grain , twill, cobwebbing, etc.
 ·Use the CE installation standard, the protect standard can be IP65.
 ·The packing function of a variety of bag type: such as: flat bags (pillow bag , three sides seal, four sides seal), solid bag (jack stand-up pouches, triangle bags), handbags, punching bags.

技术参数 Technical parameters

机型(Type)	DBIV-620	DBIV-520	DBIV-420	DBIV-320
薄膜最大宽度(max width of roll film)	620mm	520mm	420mm	320mm
最大制袋宽度(Bag-making size)	300mm	250mm	200mm	150mm
最长袋长(Bag length)	400mm	400mm	300mm	200mm
计量范围(Measuring range)	8000ml	4000ml	2000ml	800ml
包装速度(Packaging speed)	2~40(bag/min)	2~60(bag/min)	2~60(bag/min)	2~60(bag/min)
包装材料(Packing material)	OPP/CPP OPP/CE PET/PE PE			
电压(Power voltage)	220VAC/50HZ			
功率(Power)	4.5KW	4.5KW	4.5KW	3.5KW
外形尺寸(Dimension)(L×W×H)mm	1400×1270×1780	1400×1170×1680	1260×1060×1400	1200×1000×1200
机器重量(Net weight)	650Kg	600Kg	550Kg	400Kg



DBIV-220

立式全自动包装机

VERTICAL AUTOMATIC PACKING MACHINE



可包装的款式 Packaging style

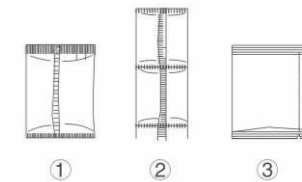

可选配置 Options

- 1. 插脚装置 Guesst device
- 2. 打孔装置 Hole punching device
- 3. "PE"膜装置 "PE"Film device
- 4. 除尘装置 Dust cleaning device
- 5. 自动纠偏装置 Automatic deviation-checking equipment
- 6. 连袋装置 Even the bag device
- 7. 真空拉膜 Vacuum film
- 8. 充气装置 Gas-filling device

产品特点 Technical characteristics

- 1. 全中文 (或英文) 显示(各国文字可根据客户要求设置) ;
- 2. 西门子触摸屏清楚显示各工作状态、操作指示等, 操作简便直观 ;
- 3. 西门子PLC提供稳定的工作程序 ;
- 4. 可预置10个产品的配方, 适应快速更换产品的包装 ;
- 5. 采用智能温控器, 温差可控制在2度以内 ;
- 6. 不停机可直接在触摸屏上调整封切位置, 纠偏等 ;
- 7. 配合横纹齿型封口, 包装更加牢固 ; 还可选用直纹、斜纹、网纹等 ;
- 8. 可采用CE安装标准, 电箱防护标准可达IP65 ;
- 9. 该包装机能制多种袋型, 如: 平面袋 (背封、三边封、四边封)、立体袋 (插口自立袋、三角袋)、手提袋、冲孔袋 ;

·Chinese (or English)screen display , (the countries words can according to the requirements of the customers).
 ·Simens PLC clearly show the working state, handle direction and so on, simple operation directly .
 ·Simens PLC system provide a stable work procedures.
 ·It can stock ten dispose, fit to the change of the product packing fastly.
 ·Using intellect thermostat , can control the temperature within 2°C.
 ·Adjust the seal position in the touch screen ,do not need to stop the machine, deviation and so on ,(more than 4230 can choose the automatic deviation).
 ·Cooperate with horizontal grain tooth type sealing, packing more firm, also can choose straight grain , twill, cobwebbing, etc.
 ·Use the CE installation standard, the protect standard can be IP65.
 ·The packing function of a variety of bag type: such as: flat bags (pillow bag , three sides seal, four sides seal), solid bag (jack stand-up pouches, triangle bags), handbags, punching bags.

技术参数 Technical parameters

机型(Type)	DBIV-220
薄膜最大宽度(max width of roll film)	220mm
最大制袋宽度(Bag-making size)	100mm
最长袋长(Bag length)	160mm
计量范围(Measuring range)	350ml
包装速度(Packaging speed)	80(bag/min)
包装材料(Packing material)	OPP/CPP OPP/CE PET/PE PE
电压(Power voltage)	220VAC/50HZ
功率(Power)	2.5KW
外形尺寸(Dimension)(L×W×H)mm	1090×720×870
机器重量(Net weight)	200Kg

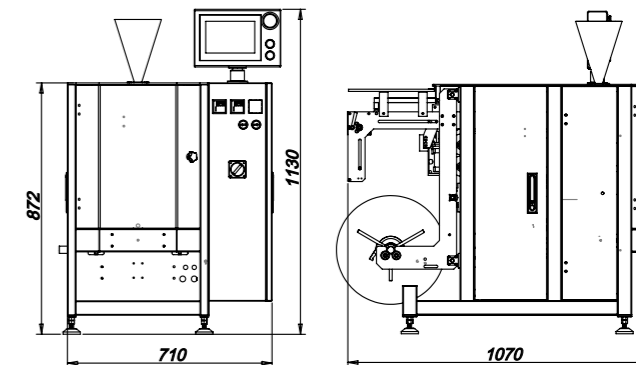

立式全自动包装机系列 VERTICAL AUTOMATIC PACKING MACHINE



DBIV-120 全自动条形包装机 AUTOMATIC STRIP PACKING MACHINE



可包装的款式
Packaging style

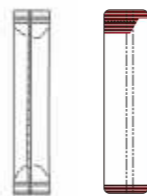

可选配置 Options

- 1. 打孔装置 Hole punching device
- 2. 连袋装置 Even the bag device
- 3. 除尘装置 Dust cleaning device
- 4. 圆角装置 Fillet device
- 5. 自动纠偏装置 Automatic deviation-checking equipment

产品特点 Technical characteristics

1. 全中文（或英文）显示(各国文字可根据客户要求设置)；
2. 西门子触摸屏清楚显示各工作状态、操作指示等，操作简便直观；
3. 西门子PLC提供稳定的工作程序；
4. 可预置10个产品的配方，适应快速更换产品的包装；
5. 采用智能温控器，温差可控制在2度以内；
6. 不停机可直接在触摸屏上调整封切位置，纠偏等；
7. 配合横纹齿型封口，包装更加牢固；还可选用直纹、斜纹、网纹等；
8. 可采用CE安装标准，电箱防护标准可达IP65；
9. 该包装机能制多种袋型，如：平面袋（背封、三边封、四边封）、立体袋（插口自立袋、三角袋）、手提袋、冲孔袋；

·Chinese (or English)screen display , (the countries words can according to the requirements of the customers).
 ·Simens PLC clearly show the working state, handle direction and so on, simple operation directly .
 ·Simens PLC system provide a stable work procedures.
 ·It can stock ten dispose, fit to the change of the product packing fastly.
 ·Using intellect thermostat , can control the temperature within 2°C.
 ·Adjust the seal position in the touch screen ,do not need to stop the machine, deviation and so on ,(more than 4230 can choose the automatic deviation).
 ·Cooperate with horizontal grain tooth type sealing, packing more firm, also can choose straight grain , twill, cobwebbing, etc.
 ·Use the CE installation standard, the protect standard can be IP65.
 ·The packing function of a variety of bag type: such as: flat bags (pillow bag , three sides seal, four sides seal), solid bag (jack stand-up pouches, triangle bags), handbags, punching bags.

技术参数 Technical parameters

机型(Type)	DBIV-120
薄膜最大宽度(max width of roll film)	220mm
最大制袋宽度(Bag-making size)	100mm
最长袋长(Bag length)	160mm
计量范围(Measuring range)	350ml
包装速度(Packaging speed)	80(bag/min)
包装材料(Packing material)	OPP/CPP OPP/CE PET/PE PE
电压(Power voltage)	220VAC/50HZ
功率(Power)	2.5KW
外形尺寸(Dimension)(L×W×H)mm	1090×720×870
机器重量(Net weight)	200Kg

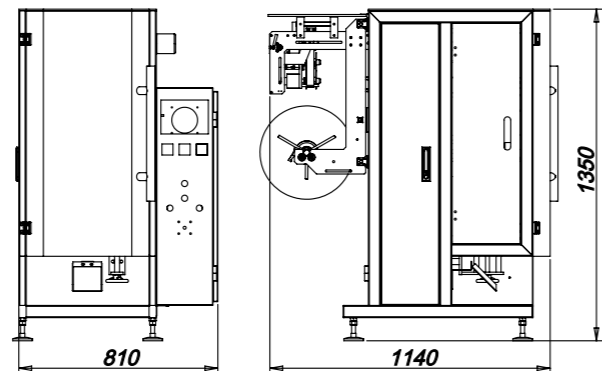

DBIV-620S/520S/420S 倾斜式包装机 INCLINED PACKING MACHINE

倾斜设计，为的是适应一些容易摔碎的产品及容易撞穿包装膜的产品。
 Inclined design is designed to adapt to some products which are easy to break down and easily break through the packaging film.



可选配置 Options

- 1. 插脚装置 Guesst device
- 2. 打孔装置 Hole punching device
- 3. "PE"膜装置 "PE"Film device
- 4. 除尘装置 Dust cleaning device
- 5. 自动纠偏装置 Automatic deviation-checking equipment
- 6. 连袋装置 Even the bag device
- 7. 真空拉膜 Vacuum film
- 8. 充气装置 Gas-filling device

产品特点 Technical characteristics

1. 采用彩色触摸屏和稳定可靠的西门子PLC控制、制袋、计量、重填、封合、打码、切袋一次性完成。
2. 可倾斜式包装，对于易碎物料的保护更有效。
3. 盒式包装袋成型好，更美观。
4. 拉膜采用伺服电机控制，实现高精度定位，尺寸准确。
5. 采用外置式放膜机构，包装膜安装更容易。
6. 纵封封合过程，自动纠偏，极大降低劳动强度。

应用范围：

适合包装颗粒状、片状、条状、粉剂，如饼干、大米、薯片、虾条、宠物食品、果冻、花生、咖啡、奶粉等产品。

Technical characteristics:

1. Simens PLC control with suitable, reliable biaxial accuracy output and color touch screen, bag-making, measuring, filling, printing, cutting, finished in one operation.
2. Slanting packaging, very useful to protect for the breakable products.
3. Box-packaging bag in more nicety.
4. Servo motors control the carrying film, high precision orientation, size more nicety.
5. External film releasing mechanism: simpler and easier installation of packing film.
6. The process of vertical sealing can adjust the volume deviation automatically, greatly reduce labor intensity.

Application:

Suitable for packing of various of granule, slice, strip, such as biscuits, rice, potato chips, shrimp ship, pet food, jelly, peanut, coffee, milk powder etc. packing with in 5000ml.

技术参数 Technical parameters

机型(Type)	DBIV-620	DBIV-520	DBIV-420
薄膜最大宽度(max width of roll film)	620mm	520mm	420mm
最大制袋宽度(Bag-making size)	300mm	250mm	200mm
最长袋长(Bag length)	400mm	400mm	300mm
计量范围(Measuring range)	8000ml	4000ml	2000ml
包装速度(Packaging speed)	2~40(bag/min)	2~60(bag/min)	2~60(bag/min)
包装材料(Packing material)	OPP/CPP OPP/CE PET/PE PE		
电压(Power voltage)	220VAC/50HZ		
功率(Power)	4.5KW	4.5KW	4.5KW
外形尺寸(Dimension)(L×W×H)mm	1400×1270×1780	1400×1170×1680	1260×1060×1400
机器重量(Net weight)	650Kg	600Kg	550Kg

立式全自动包装机系列 VERTICAL AUTOMATIC PACKING MACHINE



DBIV-820A/720A/520A 全自动烫四边包装机 IRONING QUADRILATERAL PACKAGING MACHINE



可包装的款式 Packaging style

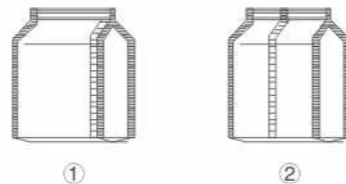

可选配置 Options

1. 打孔装置 Hole punching device
2. "PE"膜装置 "PE" Film device
3. 除尘装置 Dust cleaning device
4. 自动纠偏装置 Automatic deviation-checking equipment
5. 连袋装置 Even the bag device
6. 充气装置 Gas-filling device

产品特点 Technical characteristics

1. 采用触摸屏和稳定可靠的PLC控制、制袋、计量、充填、封合、打码、切袋一次性完成；
2. 盒式包装袋成型，更美观；
3. 拉膜采用伺服电机控制，实现高精度定位，尺寸准确；
4. 采用外置式放膜机构，包装膜安装更容易；
5. 纵封封合过程，自动调整偏差量，极大降低劳动强度；
6. 制袋形式折角烫边，新颖高档，是当今世界主流袋形。

Technical characteristics

- PLC control with stable, reliable biaxial high accuracy output and color touch screen, bag-making, measuring, filling, printing, cutting, finished in one operation.
- Box-packaging bag is more nicety.
- Servo motors control the car, rying film, high precision orientation, size more nicety.
- External film releasing mechanism: simpler and easier installation of packing film.
- The process of vertical sealing can adjust the volume deviation automatically, greatly reduce labor intensity.
- Stand bag with burns edges, 4 sides seal edges, novelty and slap-up, and the mainstream bag shape.

技术参数 Technical parameters

机型(Type)	DBIV-820A	DBIV-720A	DBIV-520A
计量范围(Measuring range)	15L	10L	6000ml
正面最宽(Front width)	240mm	200mm	160mm
侧面宽(Side width)	40~128mm	40~105mm	40~80mm
边封宽(With of side seal)	5~10mm	5~10mm	5~10mm
最长袋长(Bag length)	500mm	400mm	400mm
包装速度(Packing speed)	10~60包/分(bags/min)	10~60包/分(bags/min)	10~60包/分(bags/min)
包装材料(Packing material)	OPP/CPP OPP/CE PET/PE	OPP/CPP OPP/CE PET/PE	OPP/CPP OPP/CE PET/PE
膜最大宽度(Max width of film roll)	620mm	520mm	420mm
电压(Power voltage)	220V/50HZ	220V/50HZ	220V/50HZ
功率(Power)	6.5KW	6KW	5.5KW
外型尺寸(Dimension)	1815(L)×1520(W)×2005(H)mm	1780(L)×1350(W)×1950(H)mm	1500(L)×1220(W)×1800(H)mm
机器重量(Net weight)	850kg	700kg	600kg



DBIV-388 立式全自动包装机 VERTICAL AUTOMATIC PACKING MACHINE



可包装的款式 Packaging style

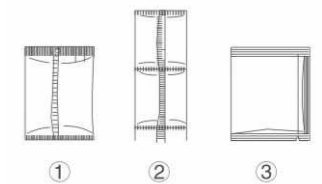

产品特点 Technical characteristics

1. 先进设计理念，操作简单。
2. 单片机控制系统，屏幕显示。
3. 使用变频调速器，关闭机器时自动打开封刀，节省材料。
4. 制袋，填充，计量，封口，印刷，成品输送一次性完成。

- Advance design idea, operation simple.
- With touch screen PLC control system, low fault rate.
- With frequency adjustment speed, sealing knife open automatic when close machine, save material.

- Bag-making, filling, measuring, sealing, printing, product convey in one operation.

适用包装范围：适合包装颗粒状、片状、条状、粉剂，如饼干、大米、薯片、虾条、宠物食品、果冻、花生、咖啡、奶粉等。

Application： suitable for packing granular, sheet, strip, powder, such as biscuits, rice, potato chips, shrimp, the pet food, jelly, peanut, coffee, milk and other products.

技术参数 Technical parameters

机型(Type)	DBIV-388
包装材料(Packing material)	OPP/CPP OPP/PE PET/PE
最大计量范围(Measuring range)max	800ml
制袋尺寸(Bag-making size)	50-200(L)×40-150(W)mm
包装速度(Packing speed)	10-70bags/min
卷膜最大宽度(Max width of film roll)	320mm
电压(Power voltage)	220V/50Hz
功率(Power)	2Kw
外型尺寸(Dimension)	1200(L)×700(W)×1600(H)mm
机器自重(Net weight)	300kg



粉剂包装机
Powder packing machine



长尾包装机
Tail packing machine

立式全自动包装机系列 VERTICAL AUTOMATIC PACKING MACHINE



DBGD-200 给袋式包装机 BAG PACKING MACHINE

包装样袋/Pouch Sample

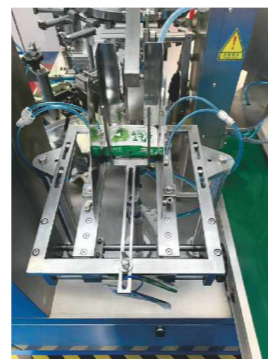

使用范围:

适合要求计量精度高及易碎的散装物料包装。如膨化食品、糖果、饼干、炒货、宠物用品、小五金件、药材等。

Application:

It is suitable for high measuring precision and easy crushed bulk material, for example: puffed food (chips), candy, biscuit, watermelon seeds, roasted seeds and nuts, pet food, hardware and medicine etc.

技术参数 Technical parameters

机型(Type)	DBGD-200
包装袋类型(Types of Packaging Bags)	自立袋、拉链袋、四边封袋、三边封袋、纸袋等复合袋
包装范围(Packaging scope)	W: 120~250mm L: 80~360mm
充填范围(Filling area)	液体、颗粒、粉末
包装速度(Packaging speed)	20-60包/分钟 (其包装速度由产品特性及充填重量决定)
包装精度(Packaging accuracy)	±1g(≤100g) ±1%(>100g) (视物料而定)
总功率(Total power)	8.5kw
压缩空气消耗量(Compressed air consumption)	1.0 m3/min (空压机客户自备)

DBHS-110/130 水平式包装机 HORIZONTAL AUTOMATIC PACKING MACHINE

- 食品 Food
- 化妆 Cosmetics
- 化工 Chemical
- 饮料 Beverages
- 制药 Pharma

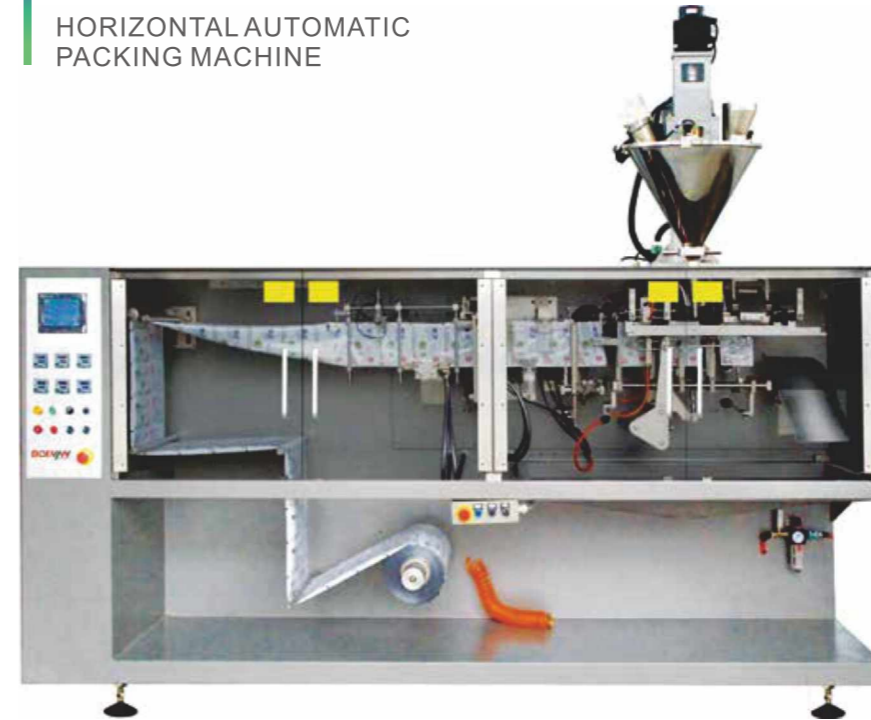

袋型/Pouch

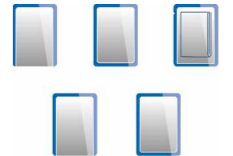

包装样袋/Pouch Sample



产品应用 | Product Application



独立的封合装置 Independent Sealing Device

独立制袋，封边无夹料
Independent pouch making, no product on seal
更高的封合强度，减少漏袋
Higher seal strength, less leakage
袋子更平整更美
Better pouch appearance

轻盈化小车 Light Walking Beam

更高的运行速度
Easy computerized spedition change
更长的使用寿命
Longer operational life span

技术参数 | Technical Parameter

型号 Model	袋宽 Pouch Width	袋长 Pouch Length	包装容量范围 Filling Capacity	包装速度 Packaging Capacity	功能 Function
DBHS-110	50-110mm	50-130mm	60ml	60-80ppm	三边封，四边封 3 side seal D4 side seal
DBHS-130	60-140mm	80-180mm	160ml	60-80ppm	三边封，四边封 3 side seal D4 side seal
功率 Power: 3.5 kw 耗气量 Air Consumption: 100 NL/min			重量 Weight: 800 kg 设备尺寸 Machine Dimensions(L*W*H): 2850×940×1400mm		

立式全自动包装机系列 VERTICAL AUTOMATIC PACKING MACHINE

DBHP-180/180D/210Z/240Z/280D/280DZ

水平式包装机

HORIZONTAL AUTOMATIC PACKING MACHINE

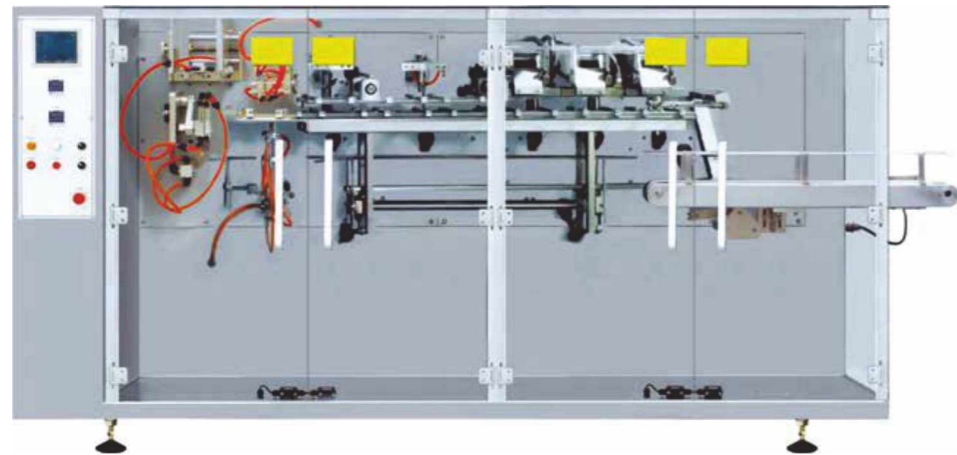

包装样袋/Pouch Sample



技术参数 | Technical Parameter

型号 Model	袋宽 Pouch Width	袋长 Pouch Length	包装容量范围 Filling Capacity	包装速度 Packaging Capacity	功能 Function
DBHP-180	60-180mm	80-225mm	400ml	60-80ppm	平袋、三边封、四边封、挂孔 Flat Pouch D 3D Hanging Hole 挂孔拉链、异形、直嘴 Zipper Euro Hole, Shape, Top Spout
DBHP-180D	60-180mm	90-225mm	400ml	120-160ppm	平袋、三边封、四边封、挂孔 Flat Pouch, 3/4 side seal, Hanging Hole 挂孔拉链、异形、直嘴 Zipper Euro Hole, Shape, Top Spout
功率 Power: 2.3 kw 重量 Weight: 800 kg 耗气量 Air Consumption: 200 NL/min 设备尺寸 Machine Dimensions(L*W*H): 2250×970×1400mm					
DBHP-210Z	90-210mm	110-300mm	1200ml	40-60ppm	平袋、自立袋、拉链 Flat Pouch, Doy Pack, Zipper
DBHP-240Z	100-240mm	120-320mm	1500ml	40-60ppm	平袋、自立袋、拉链 Flat Pouch, Doy Pack, Zipper
功率 Power: 4.5 kw 重量 Weight: 1100 kg 耗气量 Air Consumption: 350 NL/min 设备尺寸 Machine Dimensions(L*W*H): 3200×980×1400mm					
DBHP-280D	90-140mm	110-260mm	800ml	90-120ppm	平袋、自立袋 Flat Pouch, Doy Pack
DBHP-280DZ	90-140mm	110-260mm	800ml	90-120ppm	平袋、自立袋、拉链 Flat Pouch, Doy Pack, Zipper
功率 Power: 4.5 kw 重量 Weight: 2000 kg 耗气量 Air Consumption: 350 NL/min 设备尺寸 Machine Dimensions(L*W*H): 5100×980×1400mm					

DBHD-130S/240DS/180S/180SZ/180SC/240S/240SZ/240SC

水平式包装机

HORIZONTAL AUTOMATIC PACKING MACHINE

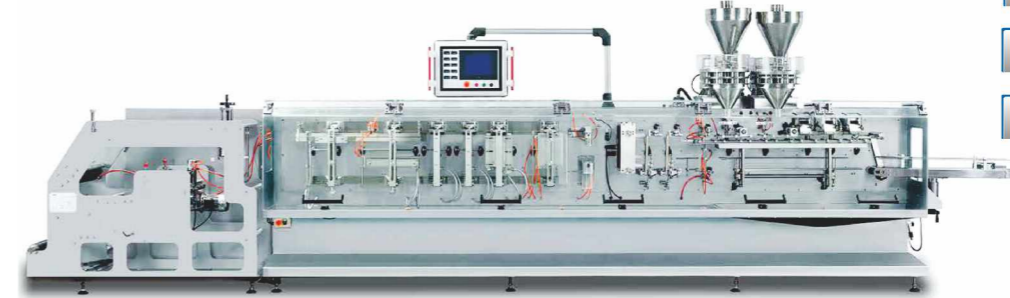

包装样袋/Pouch Sample



技术参数 | Technical Parameter

型号 Model	袋宽 Pouch Width	袋长 Pouch Length	包装容量范围 Filling Capacity	包装速度 Packaging Capacity	功能 Function
DBHD-130S	60-130mm	80-1	160ml	35-45ppm	自立袋、异形 Doy Pack, S Shape
DBHD-240DS	80-120mm	120-250mm	500ml	80-100ppm	自立袋、异形 Doy Pack, S Shape
功率 Power: 6 / 11 kw 重量 Weight: 1000 kg / 2800 kg 耗气量 Air Consumption: 300/400 NL/min 设备尺寸 Machine Dimensions(L*W*H): 4500mm×940mm×2150mm 7500mm×1250mm×1550mm					
DBHD-180S	90-180mm	110-250mm	1000ml	40-60ppm	自立袋、异形、挂孔 Doy Pack, S Shape, Hanging Hole
DBHD-180SZ	90-180mm	110-250mm	1000ml	40-60ppm	自立袋、异形、挂孔、拉链 Doy Pack, S Shape, Hanging Hole, Zipper
DBHD-180SC	90-180mm	110-250mm	1000ml	40-60ppm	自立袋、异形、挂孔、吸嘴 Doy Pack, Shape, Hanging Hole, Spout
功率 Power: 9kw 重量 Weight: 2100kg 耗气量 Air Consumption: 300 NL/min 设备尺寸 Machine Dimensions(L*W*H): 6000×1100×1500mm					
DBHD-240S	100-240mm	120-320mm	1500ml	40-60ppm	自立袋、异形、挂孔 Doy Pack, S Shape, Hanging Hole
DBHD-240SZ	100-240mm	120-320mm	1500ml	40-60ppm	自立袋、异形、挂孔、拉链 Doy Pack, S Shape, Hanging Hole, Zipper
DBHD-240SC	100-240mm	120-320mm	1500ml	40-60ppm	自立袋、异形、挂孔、吸嘴 Doy Pack, Shape, Hanging Hole, Spout
功率 Power: 11kw 重量 Weight: 2800kg 耗气量 Air Consumption: 400 NL/min 设备尺寸 Machine Dimensions(L*W*H): 8700×1250×1550mm					

螺杆机配套系列 SCREW MACHINE SERIES

DBS-30 螺杆计量机
SPIRAL FEEDER



DBS-50 螺杆计量机
SPIRAL FEEDER



DBS-80 螺杆计量机
SPIRAL FEEDER



产品特点 Technical characteristics

该机是专门针对粉末、超细粉末状等物料而设计制造，能自动完成计量、充填、充氮等工作。能够与各种制袋包装机配套，用作计量充填粉末状物料。适用于包装那些易流动或流动性极差的粉粒状物料，如奶粉、饲料、米粉、白糖、味精、固体饮料、葡萄糖、米粉、食品添加剂、营养食品、染料、香精香料等。

As it is designed and produced for powder or ultrafine powder materials, the machine can automatically finish bag making, metering, filling and nitrogen charging. It can be matched with various bag-making packing machines for metering powder materials to be filled, and suitable for packing powder materials, which are easy to flow or extremely poor in flowability, such as milk powder, feed, rice flour, sugar, monosodium glutamate, powdered drinks, glucose, food additives, nutritious food, dyes, essence and spice.

可选附件：

- 1、PLC人机界面电控箱；
- 2、气动阀门止漏装置；
- 3、充氮气装置；
- 4、高精度料位接近开关。

Optional Accessories:

- 1, the PLC Human-computer interface, electronic control box;
- 2, the pneumatic valve the stanch device;
- 3, nitrogen filling device;
- 4, high-precision materials and proximity switch.

技术参数 Technical parameters

型号 Model	DBS-30	DBS-50	DBS-80
料仓容积 Hopper capacity	30L	50L	80L
包装重量 Package weight	5~1000g	10~5000g	5~40Kg
包装精度 Packing Accuracy	100~500g±1.5%	< 100g < ±2%	5~25Kg±0.5%
填充速度 Fill rate	40~120 Once/Min	40~120 Once/Min	5~6 bag/Min
电源 Power		50/60HZ 220V/380V	
整机功率 Total Power	1.2KW	2.4KW	3.4KW
整机重量 The whole weight	180kg	220kg	300kg
整机体积 Whole volume	L850×W500×H900mm	L1000×W650×H1000mm	L1105×W700×H1360mm



水平门开启
LEVEL DOOR OPEN



直线式粉末灌装线
LINEAR POWDER FILLING LINE



网状料筒



单边开门料筒



半球状活门料筒



配套计量螺杆

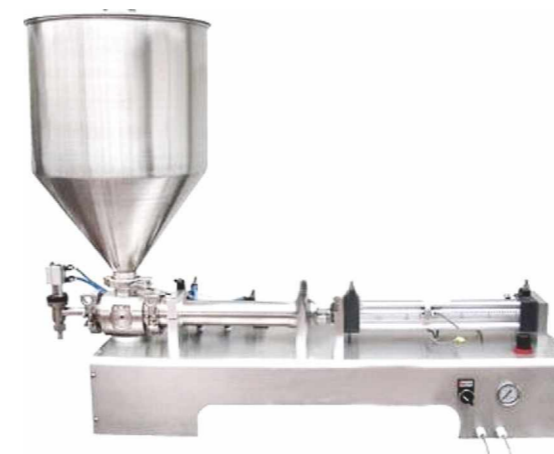

气动柱塞泵

Pneumatic plunger pump

技术参数 Technical parameters

型号 Model	DB-100	DB-500	DB-1000
灌装范围 Filling range	10-100 ml	50-500 ml	100-1000 ml
速度 Packing speed	25 Second / minute		
储料斗容积 Storage hopper capacity	20 L	20 L	38 L
电源 Power supply	220VAC/50Hz	220VAC/50Hz	220VAC/50Hz

14头电子组合沙拉秤

14 HEAD OF ELECTRONIC SCALE COMBINATION SALAD



适应范围

适用于轻、体积较大的沙拉秤重，使用范围更广。

主要功能

- ◆ 单独调节振幅，操作更为方便。
- ◆ 多国语言操作系统。
- ◆ 控制秤重依次放料功能，避免物料堵塞。

独特优势

- ◆ 控制系统模块化，维护方便，成本低。
- ◆ 专业数字秤重模块，稳定性更好，精度高

Application:

Application it is suitable for the light, larger salad weighing and widely used.

Main function:

- ◆ Amplitude modulation alone, more convenient to control.
- ◆ Multilingual system
- ◆ Control weighing function, make the material into the weigher in turn, avoid blocking up at charging area.

Unique advantage:

- ◆ The modularized for control system, more convenient for maintenance and low cost.
- ◆ Professional digital weighing module, good stability, high accuracy.
- ◆ The modularized for the stepper motor drive, more convenient for maintenance and low cost.

型号Model	DB-10A 5L	DB-14A 5L
秤重范围Measuring range	50-6500g	50-6500g
精度Accuracy	±1-5g	±1-5g
最高速度Max speed	60bags/min	120bags/min
秤重容积Hopper volume	5L	5L
显示器Displayer	7/10.4寸触摸屏 7/10.4 inches touch screen	
选购装置Options	花纹称斗/集料斗/分料装置 Pattern Bulk Hopper/Collection Hopper/Feed Divider	
预设参数Preset parameter	99种/99 kinds	
电源电压Power requirements	AC 110V/220V 50Hz/60Hz	
功率Power	1.5kw	2kw



DB-14 14头电子组合称

14 HEAD ELECTRONIC SCALE COMBINATION



DB-10 10头电子组合称

10 HEAD ELECTRONIC SCALE COMBINATION



主要性能和结构特点

适应范围:

适合于要求计量精度高及易碎的散状物体的包装，如：膨化食品、薯片、锅巴、果冻、糖果、开心果、花生、豆子、苹果片、水饺、汤圆、药材、蔬菜、水果等。

主要功能:

- ◆ 单独调节振幅，操作更为方便
- ◆ 多国语言操作系统
- ◆ 控制秤重依次放料功能，避免物料堵塞

独特优势:

- ◆ 不锈钢制造，全焊，圆形的拐角，最少的灰尘积坠
- ◆ 控制系统模块化，维护方便，成本低
- ◆ 专业数字称重模块，稳定性更好，精度高
- ◆ 步进电机驱动器模块化，维护更方便，成本低
- ◆ IP65等级防水、防尘设计，更适合潮湿，多尘工作
- ◆ 汽车级电路设计，稳定的机械设计+优秀的钣金工艺

The adaptation range:

Suitable for bulk object requirements of measurement accuracy and fragile packaging, such as: puffed food, potato chips, crispy rice, jelly, candy, pistachio nuts, peanuts, beans, apple slices, Boiled dumplings, Glutinous Rice Balls, herbs, vegetables, fruit, etc..

The main function of:

- ◆ Individually adjustable amplitude, the operation is more convenient
- ◆ Multi language operating system.
- ◆ Control weighing in turn discharge function, avoid material blockage

The unique advantage:

- ◆ Stainless steel, welded, rounded corners, minimal dust fall.
- ◆ Control system of modularization, convenient maintenance, low cost.
- ◆ Professional digital weighing module, better stability, high accuracy.
- ◆ Stepper motor driver module, convenient maintenance, low cost.
- ◆ IP65 grade waterproof, dustproof design, more suitable for damp, dusty work.
- ◆ Automobile circuit design, mechanical design of sheet metal process + stable good.

技术参数/Technical parameters

型号Model	DB-14 1.6L	DB-14 2.5L	DB-10 1.6L	DB-10 2.5L
称重范围Measuring range	3-6500g	3-6500g	3-6500g	3-6500g
精度Accuracy	±0.1-2.5g	±0.2-3g	±0.3-3g	±0.3-3g
最高速度Max speed	120bags/min	120bag/min	80bags/min	80bag/min
称重容积Hopper volume	1.6L	2.5L	1.6L	2.5L
显示器Monitor	7/10.4寸触摸屏 7/10.4 inches touch screen			
选购装置Options	花纹称斗/集料斗/分料装置 Pattern Bulk Hopper/Collection Hopper/Feed Divider			
预设参数Default parameters	99种/99 kinds			
电源电压 Power requirements	AC 110V/220V 50Hz/60Hz/2KW		AC 110V/220V 50Hz/60Hz/1.5KW	
包装尺寸Packing dimension	1140*1140*1230mm+1090*850*860mm		1120*1120*1220mm+1050*770*750mm	
包装重量Net weight	500kg	520kg	420kg	450kg

检测设备系列 TESTING EQUIPMENT SERIES

DB-E1 金属检测机

METAL DETECTOR

适用范围：

用于检测食品、药品等生产过程中混入的金属异物，食品安全的必要检测步骤。

特殊功能：

- 检测灵敏度高、稳定性强、操作简便；
- 不锈钢探头和机架（可选），清洁、美观；
- 双排线性LED指示灯，分别指示铁和非铁的实时感应度，可独立调节。

Application:

It's suitable for detecting the metal materials from the tool, garments, food and chemistry industry field requirements.

Special Features:

- It is high sensitive and stable performance with easy operation;
- Compact; 304#SS frame construction (option);
- Twin-wire LED indicator can be adjusted in detecting;



技术参数 Technical parameters

型号(Model)	DB-E1	
探测方式(Detecting Range)	平衡线圈	Balancing Coil
检测范围(Detection Range)	600(L)×100~400(W)mm	600(L)×100~400(W)mm
输送速度(Conveying Speed)	25~35m/min	25~35m/min
报警方式(Alarm mode)	声光报警	Sound-Light alarm
剔除装置(Rejecting device)	气动/推杆/下落式/分段分选(可选)	Air/Pusher/Drop Down/Select(Option)
电源(Power)	AC220V±10%	AC220V±10%
机器尺寸(Dimension)	1145(L)×560(W)×1200(H)mm	1145(L)×560(W)×1200(H)mm
重量(Weight)	10Kg	10Kg

DB-E2 重量检测机

CHECKING WEIGHER

1.适用范围:

* 用于检测单个产品重量与设定目标是否相符，并由分选装置自动剔除不合格标准的产品。

2.结构特点:

- * 采用世界先进的数字式称重单元，实现高速、稳定检测。
- * 触摸屏显示操作系统、中英文操作界面，方便易学。
- * 强大的数据统计功能，记录每班的检测数据。
- * 产品零部件易于拆卸，具IP66级防水性能。
- * 储存10组不同重量规格的参数。

Application:

It is used to check whether the single bag weight is conformed to the preset weight or not, and auto remove off the unqualified products by the selecting device.

Features:

- * Adopt advanced digital load cell to obtain high-speed and stable weighing;
- * User-friendly touch screen with chinese and English languages;
- * It can record each operation due to the strong date statistic function;
- * It is convenient to maintain due to unloading belt;
- * Frame with IP65 protection and 10 preset product data models.



技术参数 Technical parameters

参数/型号(Items/Specifications)	标准重量分区(Standard Weight Range)				
	10~99g	100~500g	501~600g	601~999g	1000~2000g
速度(包/分)(Speed(Bags/Min))	65	60	50	50	30~45
精度(Accuracy)(g)	±0.5g	±0.5g	±0.5g	±1g	±2g
最小刻度(Min.Scale)(g)	0.1	0.1	0.1	0.1	0.1
产品预设模式(种)(Product Preset Programs)	10	10	10	10	10
机器尺寸(mm)/重量(Dimension(mm)/Weight)	1380(L)×560(W)×1200(H)/150Kg				
剔除机构(Reject System)	气动/推杆/下落式/分段分选(Pneumatic/Pusher/Diverter/Drop)				
电源要求/频率/功率(Voltage/Frequency/Power)	AC200 V±10%/5Hz/750W				
带面高度/输送带尺寸(Belt Height/Size)	700±80mm/350×180mm(可根据需要设计)(Depend on requirements)				



DB-Z300/Z360/Z380/Z540

Z型提升机系列

Z TYPE MATERIAL ELEVATOR



主要性能和结构特点 Function And Structure Characteristics

1. 该提升机与电子计量秤配套使用，并用控制电路以料位控制，实现自动供料和停止的自动化功能。
 2. 该提升机有不锈钢和碳钢两种材料制作，供用户选择。可按用户要求定制不同规格。
- The elevator and electronic metering scale shall be used together, control circuit is used to control the position of the material, realizing automatic feeding and stopping function.
 - The elevator can be made of stainless steel and carbon steel according to the customer choice.

适用范围 Scope or Application

适合于各种易碎和不易碎物料提升，如薯片、虾条、锅巴、各种五金类、药品类、化工原料、粮食饲料、陶瓷原料等。Suitable for a variety of fragile and non-friable material hoist, such as potato chips, prawn crackers, crispy rice, all kinds of Hardware, medicine, chemical raw materials, grain feed, ceramic raw materials.

技术参数 Technical parameters

机型(Type)	DB-Z300	DB-Z360	DB-Z380	DB-Z540
功率(Power)	0.55~0.75KW	0.75~1.1KW	0.75~1.5KW	1.5~3.7KW
输送量(Conveying capacity)	1~4m³/h	3~8m³/h	5~12m³/h	9~20m³/h
输送斗(食品级PP料)(Conveyor bucket)	1L(300×115×55)	2L(420×140×70)	4L(480×200×105)	8L(540×240×130)
电压(Voltage)	220V/380V			
毛重(Gross weight)	380KG	480KG	560KG	700KG
包装尺寸(Package Size)	L1800×W800×H900	L2000×W900×H1050	L2300×W1000×H1250	L2600×W1100×H1350



DB-L370
链板式大倾角输送机
LARGE INCLINATION HOIST

主要性能和结构特点 Function And Structure Characteristics

- 1、该提升机与电子计量秤配套使用，并用控制电路以料位控制，实现自动供料和停止的自动化功能。
 - 2、该提升机有不锈钢和碳钢两种材料制作，供用户选择。可按用户要求定制不同规格。
- The elevator and electronic metering scale shall be used together, control circuit is used to control the position of the material, realizing automatic feeding and stopping function.
 - The elevator can be made of stainless steel and carbon steel according to the customer choice.

适用范围 Scope or Application

适合于各种易碎和不易碎物料提升，如薯片、虾条、锅巴、各种五金类、药品类等。
Is applicable for the lifting of frangible and non-frangible material such as potato slice, prawn cracker, crispy rice, metals and medicines etc.

技术参数 Technical parameters

机型(Type)	DB-L370
功率(Power)	0.55~1.1KW
输送量(Conveying capacity)	2~6m³/h
电压(Voltage)	220V/380V
毛重(Gross weight)	500KG



DB-250D
单斗提升机
SINGER HOPPER ELEVATOR

技术参数 Technical parameters

机器型号(Model)	DB-250D
输送高度(Convey height)	2500mm
整机功率(power)	450W
最大输送量(Convey measure)	8times/min
外型尺寸(Dimension)	900(L)×750(W)×3300(H)mm



DB-F230
螺杆上料机 SPIRAL FEEDER

产品特点 Technical characteristics

该振动螺旋上料机能够提升多种粉粒物料，可以与包装机配套，实现料位跟踪自动供料，也可单独在其它场合使用。除电机、轴承外其余材料为不锈钢，机架材料可选碳钢或不锈钢。
The vibrating spiral feeder can lift various powder materials, match with packing machine to realize material level tracking and automatic feeding, and also be used independently in other places. It is made of stainless steel



DB-Y230
螺杆上料机 SPIRAL FEEDER

技术参数 Technical parameters

提升量	To enhance the volume	1~8M³/h
料仓容积	Hopper volume	200L
上料管径	Feeding diameter	Φ80~159
提升高度	Lifting height	1.2~3.6M
电源	Power	380V 50HZ 0.75~3KW
整机重量	The whole weight	60~220KG
提升角度	Enhance the angle	45o(30°~60°)

DB-200
成品输送机

FINISHED PRODUCT CONVEYOR



技术参数 Technical parameters

机器型号(Model)	DB-200	DB-1000
输送高度(Convey height)	800mm	1200mm
整机功率(power)	40W	250W
最大输送量(Convey measure)	50-300mm/s可调	50-300mm/s可调
外型尺寸(Dimension)	1300(L)×430(W)×890(H)mm	2190(L)×437(W)×1050(H)mm



DB-400
成品输送机

PRODUCT CONVEYOR



DB-P120
旋转料理盘

ROTATING DISK

DB-KT200
快退式输送机

REWIND CONVEYOR
(水平运动输送机)



技术参数 Technical parameters

机型(Type)	DB-KT200
功率(Power)	1.1~1.5KW
输送量(Conveying capacity)	10m³/h
电压(Voltage)	220/380V
毛重(Gross weight)	300KG

适用：水平运动送料，怕挤压、振动易破碎、易分层和表面粘有易脱落调料的物料，如焙烤品、膨化食品、薯片、速冻食品、糖果等对输送设备要求很高的物料。

Apply: the horizontal movement of the feed, afraid to squeeze, the vibration is easily broken, easily layered and surface sticky materials easy to fall off the seasoning demanding materials, such as baked goods, puffed food, potato chips, frozen food, candy and other transportation equipment.

DB-D100
振动给料机

VIBRATING FEEDER



技术参数 Technical parameters

机型(Type)	DB-D100
功率(Power)	0.6KW
输送量(Conveying capacity)	0~10m³/h
电压(Voltage)	220
毛重(Gross weight)	120KG

本机采用电磁振原理作动力，具有稳定、高速、输送量大（10m³/h），而且近乎零噪音。广泛适应于膨化食品、粮食、塑料粒、饼干等的贮料输送。并能与提升机、组合称、包装机组成食品定量自动包装系统，广泛应用于食品包装行业。

This machine adopts electromagnetic vibration principle for power, with a stable, high-speed conveying capacity (10m³/h), and almost zero noise. Widely adapted to the puffed food, grain, plastic pellets, biscuits and other storage material handling. And elevator, the combination of packaging machine automatic packaging system for food rations, are widely used in food packaging industry.